

### General Guidelines For The Deep6:

1. Whenever moving the **Deep6**, use two persons and carry by grasping the frame.
2. If your **Deep6** has a light colored fabric on the face, it may be a good idea to wear white cotton gloves so dirt, grease or grime from the skin is not transferred to the fabric. If the **Deep6** is laid face down when unpacking or during installation, be sure the surface is clean and padded to avoid damaging the front surface.
3. Pre-position the **Deep6** with a laser level (preferred), hand level or chalk line to ensure uniform installation. If multiple **Deep6** panels are being placed directly up against one another, use the first installed panel as a reference point for the adjoining panels to be installed.
4. Make sure the wall has a completely flat surface. Shim the mounting clips if necessary to create a uniform front surface.

**NOTE: Standard impaling clips (included) and corner impaling clips (sold separately) are only used for wall and vertical corner installations, respectively. The Deep6 is not suitable for ceiling installations.**

### Recommended Additional Installation Materials

• Power Drill	• Tape Measure
• Carpenters Level	• Small Ladder (Depending on ceiling height)
• Pencil	• Appropriate Wall Anchors
• Straight Edge	• Stud Finder

### Installation Notes When Using Impaling Clips:

- Fasten impaling clips to the wall using 2"-3" wood screws into a stud location or appropriate drywall/masonry anchors, depending on wall construction.
- Shim the clips as necessary to ensure the front edge of the **Deep6** is flush with adjoining panels.
- Do not apply excessive pressure to a single or multiple small locations on the face of the **Deep6** so as to crush or dent the fiberglass face.
- This installation method will leave a 3/4" reveal between the top of the **Deep6** and the ceiling. When installing a vertical array of panels start at the bottom and work up toward the ceiling. Leave at least 3/4" space between the ceiling and the top of the uppermost panel in the installed position.

### Wall Mount Installation

1. Mark vertical and horizontal lines indicating placement of the **Deep6**.
2. Install impaling clips 4" in from the vertical lines to avoid metal frame and evenly space vertically.
3. Align the **Deep6** with the marks on the wall and 3/4" above its intended final height and press downward at a 45° angle until the unit is flush with the wall.

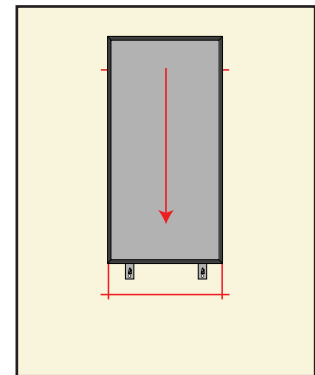
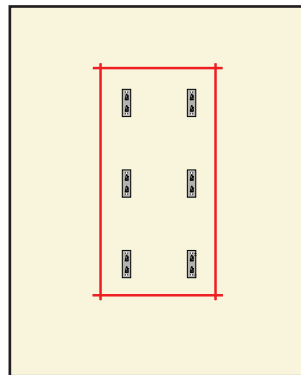
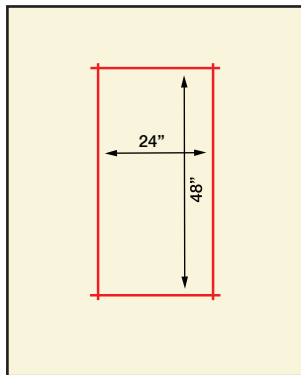

**Auralex® Acoustics, Inc.**

1-800-959-3343 | 317-842-2600 | Auralex.com  
 9955 Westpoint Drive, Suite 101, Indianapolis IN USA 46256

1238-1014.Deep6 User Guide (01/13/2020 - 9:25 AM)

### Corner/Bass Trap

- 1 Mark lines 16 7/8" on both sides of the target corner.

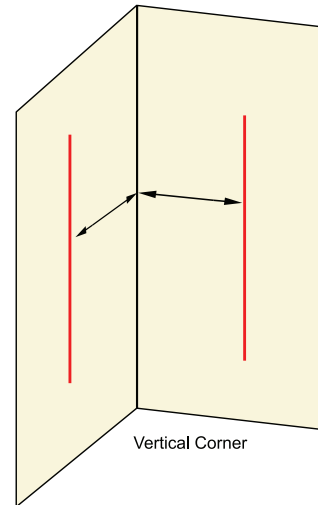

- 2 Determine clip orientation (*left/right*) and use a felt tip marker to indicate clip position and which side will face up. Twist out the top facing tips of the impaling points to a 45° angle relative to the clip face.  
Use the smaller set of points for vertical corners, the larger points are not used for **Deep6** installations.  
Align the front fold of the clip with your marked lines and attach to the wall.

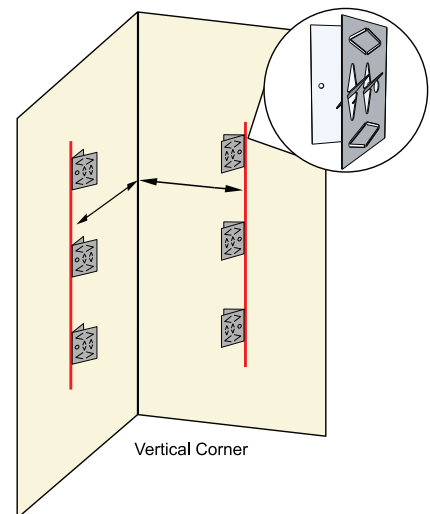

- 3 Align the panel 3/4" above its target height and press down at a 45° angle until flush with the wall.

